

ERASER MDP™

PRIMARY CONVEYOR BELT CLEANING SYSTEM

The Eraser MDP system is a rugged mine duty system, designed for extremely abusive environments with an 11.25" (286 mm) polyurethane blade. It is the same height and profile as the Eraser SHD, except in a single-blade style without the replaceable tip. This system uses our Super Eraser's .25" (6 mm) thick, 3.5" x 3.5" (89 mm x 89 mm) tube stock steel mainframe and corrosion-resistant, powder-coated stub ends for long lasting durability.

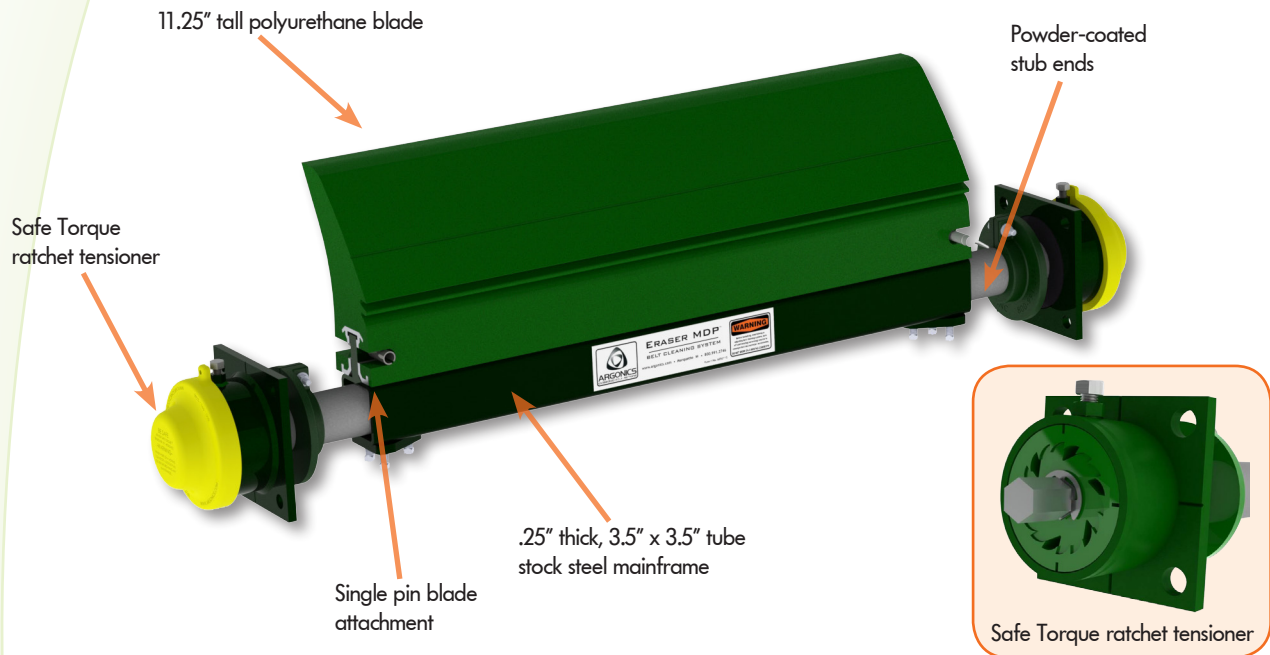

BENEFITS

- For use on conveyors with large head pulleys, big loads, harsh conditions and/or fast belt speeds
- Extremely effective cleaning performance with an 11.25" (286 mm) polyurethane blade and rugged mainframe
- The Perma-Torque™ internal central tensioner is adjustable from 30 to 135 ft-lb (40 to 183 Nm) resulting in uniform cleaning pressure to the conveyor belt
- Compact mounting footprint only protrudes 5.5" (140 mm) from mounting structure
- Safety yellow colored end caps seal the Safe Torque™ ratchet from dust and water contamination
- Single pin blade attachment means quick blade change out with less downtime

BLADES

- N62 Ether**
Normally used for extremely wet applications, sands & fines
- B93 Ester**
Our high temperature cleaning blade, up to 250°F (121°C)
- R80 Ether**
Good for wet applications with any pH level
- FO83 Ester**
MSHA approved Front Line® flame-retardant cleaning blade
- G83 Ester**
Our standard, high abrasion-resistant all-purpose cleaning blade
- RU83 Ester**
Flame retardant, anti-static cleaning blade
- U90**
Good for dry applications with any pH level



ARGONICS
ENGINEERED POLYURETHANE

SIZING INFORMATION

Dimensions - in. (mm)

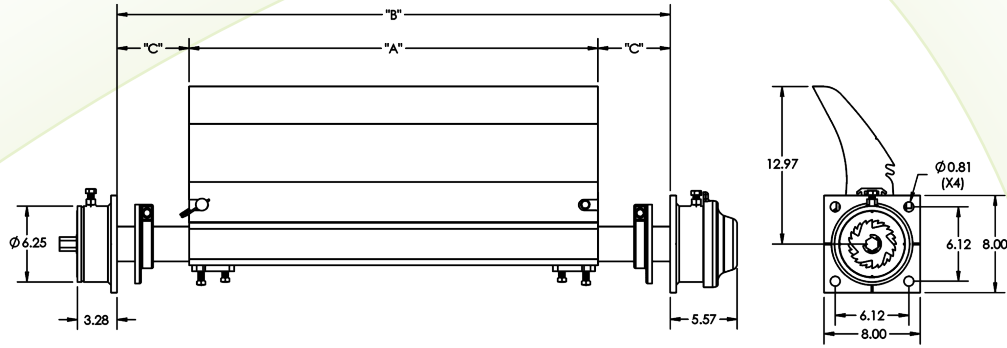

Part Number	A		Min B.		Max B.		Min C.		Max C.		Shipping Weight	
	inches	(mm)	inches	(mm)	inches	(mm)	inches	(mm)	inches	(mm)	lbs	(kg)
CP-MDP-A28D-G83	28.00	(711)	50.00	(1270)	56.00	(1422)	11.00	(279)	14.00	(356)	166.90	(76)
CP-MDP-A34D-G83	34.00	(864)	50.00	(1270)	62.00	(1575)	8.00	(203)	14.00	(356)	185.00	(84)
CP-MDP-A40D-G83	40.00	(1016)	50.00	(1270)	68.00	(1727)	5.00	(127)	14.00	(356)	203.20	(92)
CP-MDP-A46D-G83	46.00	(1168)	50.00	(1270)	74.00	(1880)	2.00	(51)	14.00	(356)	221.50	(100)
CP-MDP-A52D-G83	52.00	(1321)	52.50	(1334)	80.00	(2032)	0.25	(6)	14.00	(356)	239.80	(109)
CP-MDP-A58D-G83	58.00	(1473)	58.50	(1486)	86.00	(2184)	0.25	(6)	14.00	(356)	258.00	(117)
CP-MDP-A70D-G83	70.00	(1778)	70.50	(1791)	98.00	(2489)	0.25	(6)	14.00	(356)	294.60	(134)
CP-MDP-A82D-G83	82.00	(2083)	82.50	(2096)	106.00	(2692)	0.25	(6)	12.00	(305)	331.10	(150)
CP-MDP-A96D-G83	96.00	(2438)	96.50	(2451)	120.00	(3048)	0.25	(6)	12.00	(305)	367.10	(167)

SPECIFICATIONS

Recommended Belt Speeds
0 - 1200 fpm (6.10 m/s)

Pulley Diameter (PD)
Minimum: 24" (610 mm)
Maximum: 60" (1524 mm)

MOUNTING INFORMATION

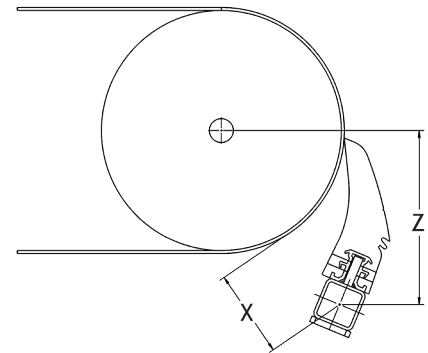

NOMENCLATURE

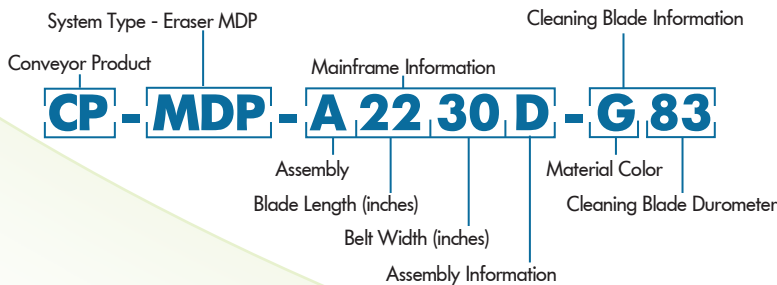

Pulley Diameter	X	Z
24" - 31" (610 mm - 788 mm)	7" (178 mm)	14.5" (368 mm)
32" - 47" (813 mm - 1194 mm)	6.5" (165 mm)	14.5" (368 mm)
48" - 60" (1220 mm - 1524 mm)	6.25" (159 mm)	14.5" (368 mm)



ARGONICS
ENGINEERED POLYURETHANE



Jamieson Equipment Company
www.jamiesonequipment.com
toll free 800.875.0280